



EBC 7500 / 9000 ELECTRICALLY BELT CONVEYOR

CHASSIS	The chassis is designed by Timsan, produced by steel plates and powered by electric motor.
CONVEYOR	The conveyor boom provides adequate number of rollers to support the belt and safe conveyance of load. The belt forward/reverse movements are provided by hydraulic motor and the height and angle adjustment are provided by hydraulic cylinders. The conveyor boom provides foldable handrail.
TRACTION SYSTEM	The traction system is provided by an 80 V AC electric motor powered with 80 V DC battery pack and controlled by high efficiency AC controller with regenerative braking system. Hydraulic assisted double circuit braking system with disc brakes is provided.
HYDRAULIC SYSTEM	The hydraulic system is provided by an oil tank, a pump driven by an engine, cylinders, hydraulic motor, hydraulic valves and some other useful accessories. Emergency hand pump is also used in case of engine failure.
SURFACES	The belt conveyor is custom painted.
ELECTRICAL SYSTEM	The electrical system is provided by work lamp, automatic starter, standard lighting for chassis and the all accessories are controlled from a control panel.
OPTIONS	9000 mm belt length, different capacity of battery pack, forklift pockets, custom painting, logo application.



Eyüpsultan Mahallesi Kartopu Sk. No: 7 34885 Sancaktepe / Istanbul / TURKEY
TEL : +90 216 527 42 70 (5 Lines) FAX : +90 216 364 33 63
e-mail: timsan@timsantr.com http://www.timsan-gse.com

TIMSAN

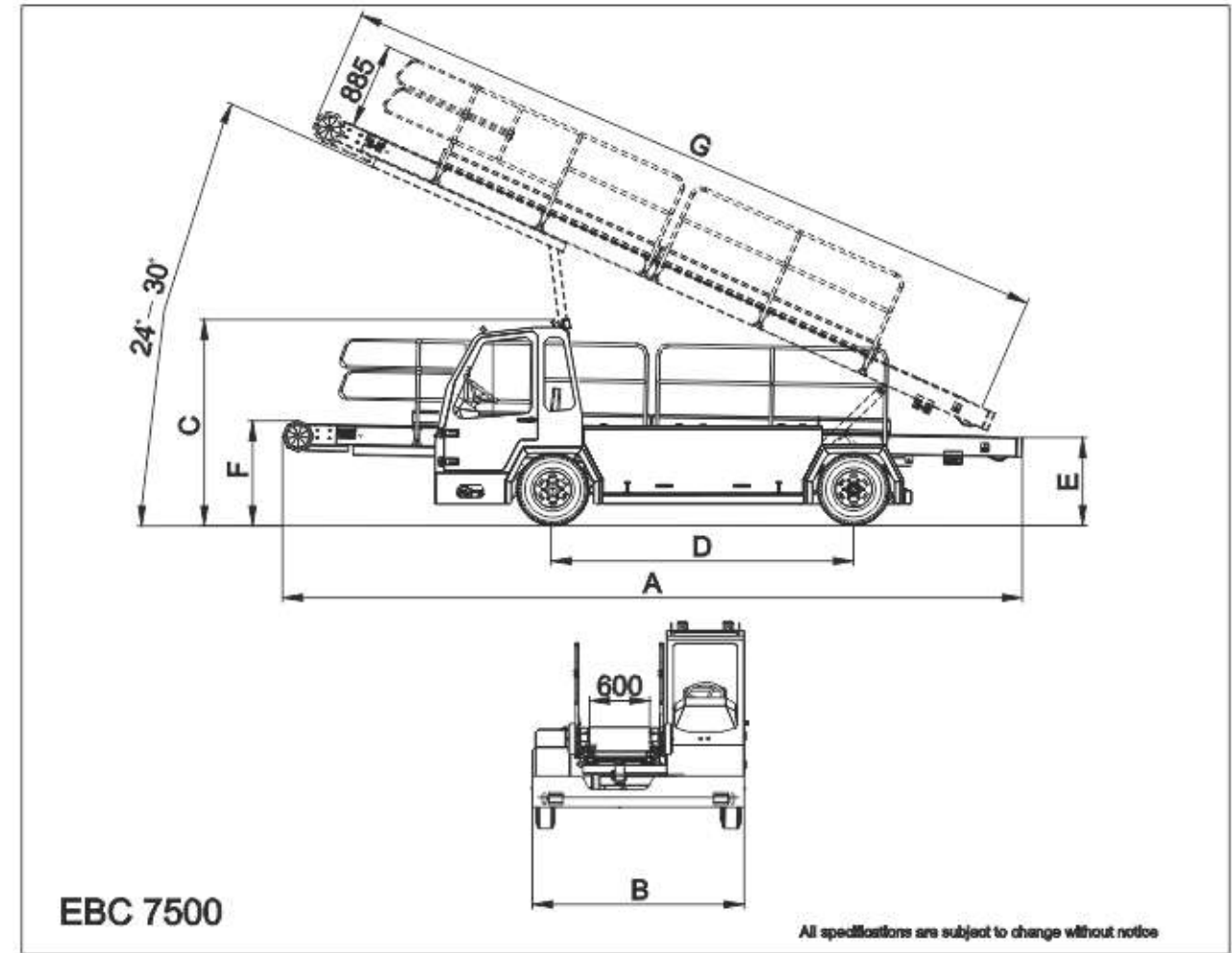

Technical Data

	EBC 7500	EBC 9000
Overall Length (A) (mm)	7625	9125
Overall Width (B) (mm)	2180	2180
Overall Height (w. cabin / w/o cabin) (C) (mm)	1915 / 2110	1915 / 2110
Wheelbase (D) (mm)	3115	3115
Servicing Height, Rear at 24° (mm)	1140	1140
Servicing Height, Front at 24° (mm)	4200	4800
Servicing Height, Rear at 30° (mm)	260	260
Servicing Height, Front at 30° (mm)	4175	4900
Servicing Height, Rear at Driving Pos. (E) (mm)	880	830
Servicing Height, Front at Driving Pos. (F) (mm)	1020	1070
Belt Length (G) (mm)	7500	9000
Belt Width (mm)	600	600
Belt Speed (m/min.)	10 - 30	10 - 30
Single Load Capacity (kg)	400	400
Continuous Load Capacity (kg)	1000	1000
Traction Motors (V / kW)	80 (AC) / 12	80 (AC) / 12
Traction Battery Pack (V / Ah)	80 / 565	80 / 565
Dead Weight (approx.) (kg)	3240	3500
Tyres (Pneumatic)	6.50"x16	6.50"x16
Max. Speed (km/h)	15	15
Shipping Dimensions (l x w x h) (mm)	7725x2280x2210	9225x2280x2210
Shipping Conditions	2 ea x 40' box	2 ea x 40' box

TIMSAN

Eyüpsultan Mahallesi Kartopu Sk. No: 7 34885 Sancaktepe / Istanbul / TURKEY
TEL : +90 216 527 42 70 (5 Lines) FAX : +90 216 364 33 63
e-mail: timsan@timsantr.com http://www.timsan-gse.com