



HELICOPTER CARRIER H C 5500

The Carriage system that we produce is designed to carry Helicopter comfortably ,safety via its control system, maneuver capability and its special hardwares.Body structure and lifting arms are designed and manufactured according to hardest conditions



SPECIFICATION (STANDARD)

- Single or Duble electric motor
- Electric Brake
- Work lamp
- Steering indicator
- Electric differential for duble electric motor
- Security for Hydraulic system
- Emergency hand pump
- Battery charger (Portable)
- Emergency stop
- Speed control valve
- Flow divider (Gear type)



Eyüpsultan Mahallesi Kartopu Sk. No: 7 34885 Sancaktepe / Istanbul / TURKEY
TEL : +90 216 527 42 70 (5 Lines) FAX : +90 216 364 33 63
e-mail: timsan@timsantr.com http://www.timsan-gse.com

TIMSAN

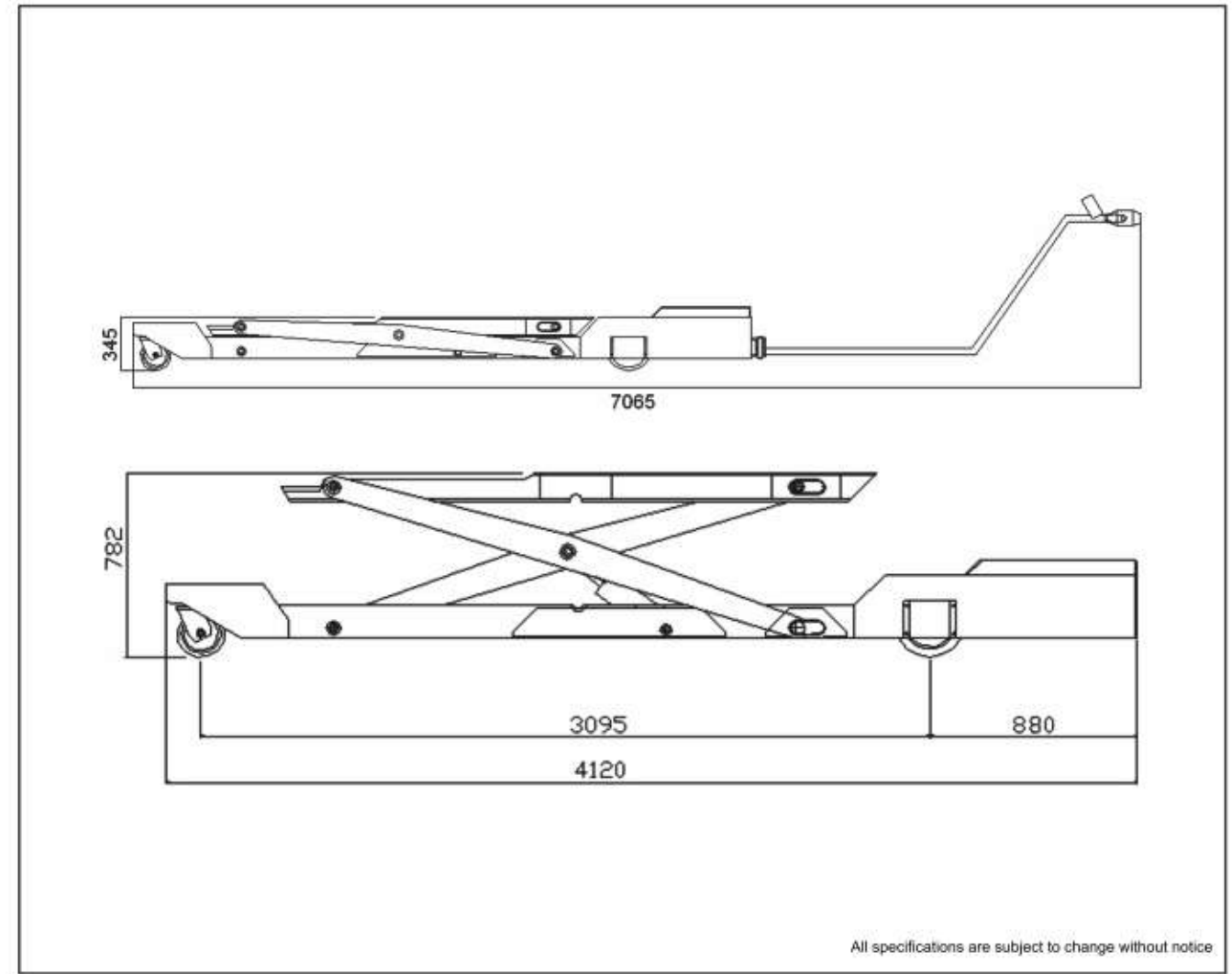

All specifications are subject to change without notice

Technical Data

HC 5500

Lenght	4120 mm - 7065 mm
Widht	1648 mm
Height	345 mm - 782 mm
Turning Radius	2675 mm
Ground Clearance (Min.)	70 mm
Carrier Capacity (max.)	5500 Kg
Electric Motor	24 V AC 2000 W. 2000 RPM
Whell (Rear)	Ø300 Vulcalon
Whell (Front)	Ø200 Vulcalon
Electrical System	24 V DC 240 Ah
Battery	4x6 V DC 240 Ah
Brake	Electrically
Lifting Platform Hydraulic system	24 V DC.3000W.4 cc Powerpack
Steering wheel Hydraulic system	24 V DC.3000W.2 cc Powerpack
Emergency Operation	Manual Hand Pump
Hydraulic Safety	Double Check Valve
Hydraulic Equipments	Speed Control Valve
	Flow divider (Gear type)

TIMSAN

Eyüpsultan Mahallesi Kartopu Sk. No: 7 34885 Sancaktepe / Istanbul / TURKEY
TEL : +90 216 527 42 70 (5 Lines) FAX : +90 216 364 33 63
e-mail: timsan@timsantr.com http://www.timsan-gse.com